

# NPPort™ PoE Module



The NPPort is the most compact, integrated solution available to PoE-enable any device with an standard RJ45 connector. By simply adding NPPort to a product design, device manufacturers cut their design cycle by as much as 80% and are able to offer PoE Ethernet connectivity in record time.

The NPPort offers the highest level of integration available in a device server. Within a compact RJ45 package is a 10/100 Ethernet transceiver, and status/diagnostic LEDs. In the space that is normally consumed by a connector, the NPPort provides a complete PoE networking interface.

NPPort is designed to provide power supply for networking devices, such as a CCTV, WLAN access point, VoIP or IP Cameras. It removes the need to access to main or external plug-top power supply.

This unit support separating power and data from any PoE enabled Ethernet via the standard Cat.5 cable. And this is the cost effective solution for embedded networking products which need support PoE

## Pin Definitions

Signal	Pin	Type	Function
VTC	1	Power	Connect to the mid-wire of transformer and LED
TX+	2	Analog	Ethernet Difference Signal
TX-	3	Analog	Ethernet Difference Signal
GND	4	GND	Ground
RX+	5	Analog	Ethernet Difference Signal
RX-	6	Analog	Ethernet Difference Signal
LD	7	Input	Driving signal for left led
RD	8	Input	Driving signal for right led
PO+	9	Power	Power output+
PO-	10	GND	Power output-
*A+	11	Power	Auxiliary power supply input+
*A--	12	GND	Auxiliary power supply input-

## PoE Product Block

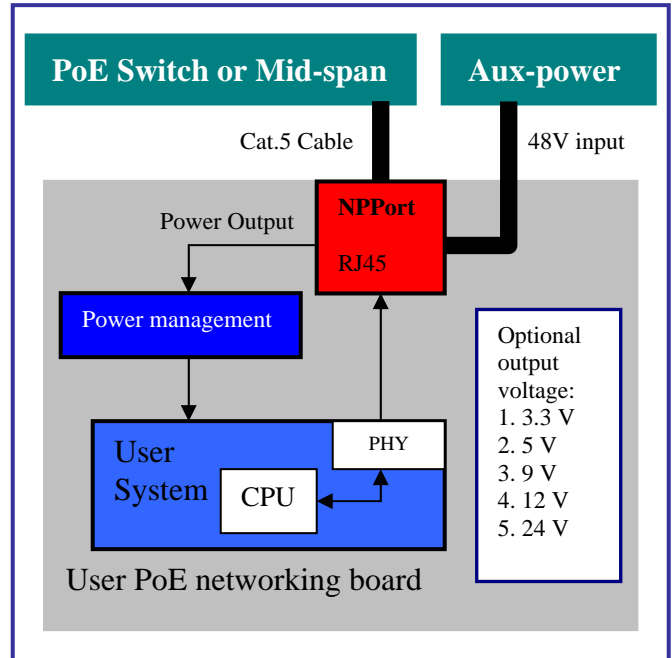

## Key Features

- IEEE802.3af compliant
- Compact RJ45 package
- Highly efficient DC/DC converter
- Low output ripple and noise
- Wide Input voltage range
- Overload and short-circuit protection
- Auxiliary Power input
- 1500V isolation (input to output)
- Simple integration

## Ideal application

- IP Camera
- VoIP phones
- Ethernet converters
- Biometric scanners
- RFID readers
- Door entry systems
- WiFi Access Points
- Point of Sale terminals
- Thin Client
- Industrial networking controllers

### LEDs

The device contains two LEDs built into the front of the NPPort connector. (See dimension drawing for location.)

Link LED (Left Side)		Activity LED (Right Side)	
Color	Meaning	Color	Meaning
Off	No Link	Off	No Activity
Green	Linked	Amber	Data Flow

### Recommended PCB Layout

The hole pattern and mounting dimensions for the NPPort are shown in the following drawing:

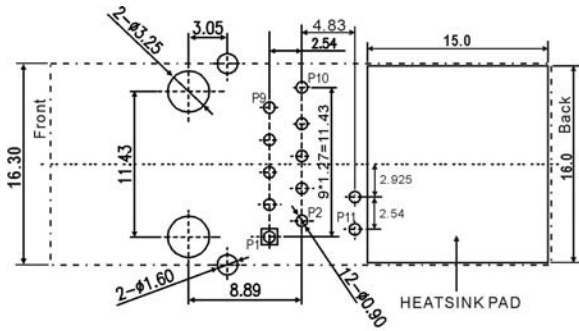

P.C.B RECOMMENDED HOLE LAYOUT SEEN FROM COMPONENT SIDE.  
ALL CENTERLINE DIMENSIONS ARE BASIC

**Note:**

Please refer to PCB layout lib for the most detailed hardware information

For proper heat dissipation, the PCB should have approximately 1 square inch of copper attached to the shield tabs. The shield tabs are an important source of heat sinking for the device.

### Dimensions

The NPPort dimensions are shown in the following drawings:

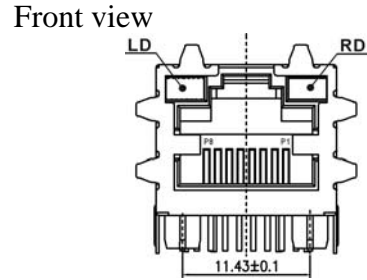

### Bottom view

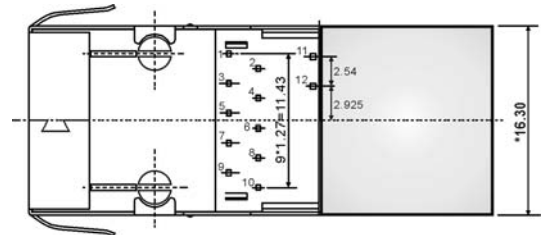

### Side view

