

SuperJack

Tab-UP RJ45



Free-Lead

CONEXTOP Technologies CO., LTD.

All rights reserved

Disclaimer

Copyright ©2007

Conextop, Inc.

All rights reserved.

CONEXTOP, NPPort, with its patent-pending technology, and NPPort marks of Conextop. All other trademarks are the property of their respective owners.

Contacts

CONEXTOP Ltd.

Room 608, 6/F, Electric Building,
High-tech Park, Nanshan,
Shenzhen, China
Phone: 86-755-26505615
Fax: 86-755-26505565

Technical Support

Online: www.conextop.com/aboutus/contactus.htm

Sales Offices

For a current list of our domestic and international sales offices, go to the CONEXTOP web site at www.conextop.com

Description

10/100 Base-TX J45 1x1 Tab-UP 10-pin Integrated magnetic Connector, designed for support compatible NPPort module, meet later need to consider supporting PoE function and high volume cost-conscious applications such as: Fire and security, Smart home, Industrial automation, Remote monitoring, POS, Test and measurement equipment, Network appliances and switches .ect

Features

- Fully compatible with NPPort (PoE module)
- IEEE802.3af compliant
- Integrated isolation type magnetic element
- Integrated electrical safety isolation capacitor
- Integrated impedance matching circuit
- Integrated LED current-limiting resistor
- Integrated TVS arrays (* option)
- Integrated Low dropout voltage Bridge Rectifier (* option)
- High quality gold plated flat pin, good contact performance
- Commercial and industrial temperature 10-pin ROHS-compliant standard RJ45 package

Contents

1. Block Diagrams	4
2. Schematic symbol	4
3. Ordering information	4
1. PRODUCT LABEL.....	4
2. PART NUMBER	5
3. PRODUCTS LIST.....	5
4. Surge Immunity ratings (TVS Array)	5
5. RJ45 interface mechanical characteristics	5
6. Pin Descriptions	6
7. 10/100BASE-TX Magnetics Modules (Electrical specifications @ 25°C)	6
8. LED characteristics	6
9. Mechanical characteristics (unit: mm).....	6
1. PRODUCTS SHELL HOLE (RECOMMENDED VALUE).....	6
2. FRONT VIEW	7
3. BOTTOM VIEW	7
4. SIDE VIEW.....	7
5. RECOMMENDED PCB LAYOUT (NPPORT FOOTPRINT).....	8

1. Block Diagrams

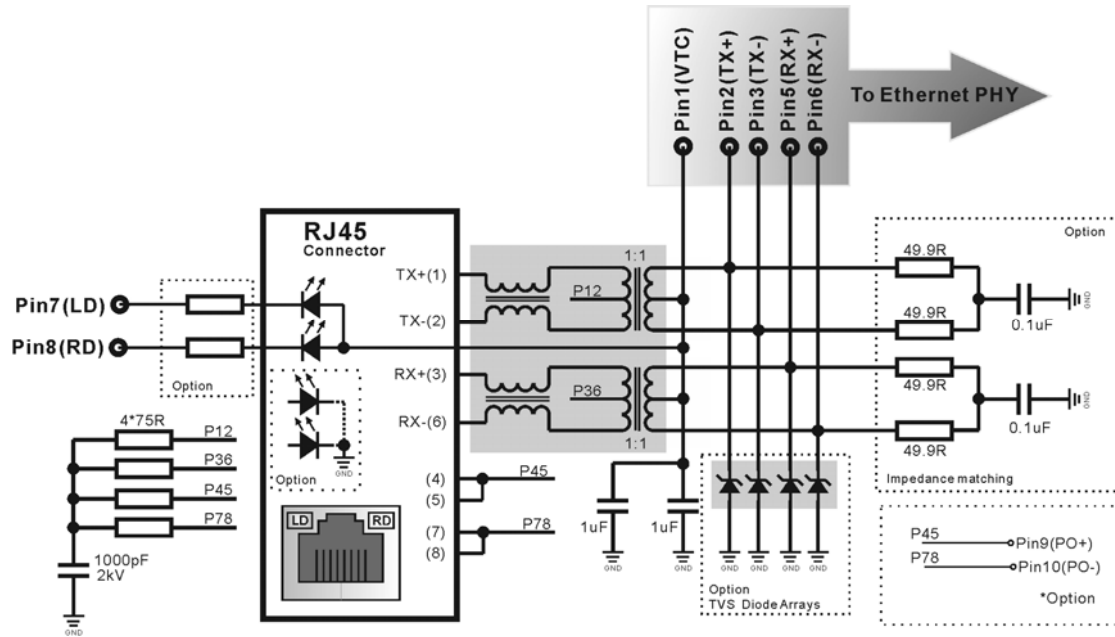

2. Schematic symbol

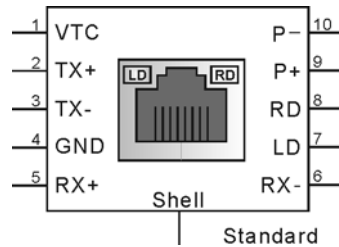

3. Ordering information

1. Product Label



2. Part Number

RJ0000011-A10

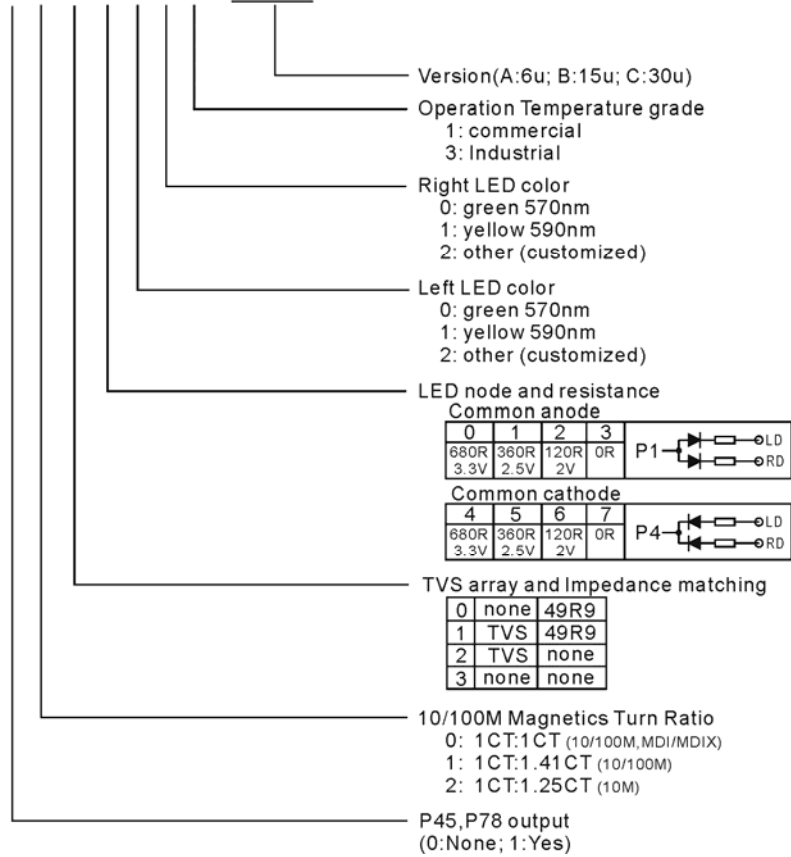

3. Products list

Name	Part Number	Description
RJ45	RJ000011-A10	Commercial, LED common anode (green+yellow)
RJ45	RJ001011-A10	Commercial, TVS array ,LED (green+yellow)
RJ45	RJ001013-A10	Industrial, TVS array ,LED (green+yellow)

Table only lists out some modules

4. Surge Immunity ratings (TVS Array)

Type	Description	Rating	Unit
ESD (system-level)	Air discharge (IEC 61000-4-2)	-16.5 to 16.5	kV
	Contact discharge (IEC 6100-4-2)	-8 to 8	kV
ESD (HBM)	JEDEC (JESD22-A114E)	-2000V to 2000	V

Note: Option, only TVS array has additional protection PHY performance

5. RJ45 interface mechanical characteristics

Item	Description
Contact:	phosphor bronze (0.35mm FLAT PIN); 6U ,15U,30U gold plating over nickel
Durability	750(modular jack) insertion/plug dimension cycles at min. rate of 120 cycles per minute
Shield	0.25mm thickness copper nickel alloy
Warning	Do not soak cleaning, otherwise it will damage the module

6. Pin Descriptions

Pin	Name	Pin Type	Description	Application Information
1	VTC	Power	This pin connect the center tap transformer or LED (Anode)	Connected to the PHY power supply (3.3V, 2.5V, 2V, 1.8V etc.)
2	TX+	Analog	Ethernet difference signal	Connected to the PHY TX+
3	TX-	Analog	Ethernet difference signal	Connected to the PHY TX-
4	GND	Ground	Signal Ground or LED(Cathode)	
5	RX+	Analog	Ethernet difference signal	Connected to the PHY RX+
6	RX-	Analog	Ethernet difference signal	Connected to the PHY RX-
7	LD	Input	Driving signal for left LED	Connected to the PHY LED pin
8	RD	Input	Driving signal for right LED	Connected to the PHY LED pin
9	PO+	Power	Positive terminal (*PoE)	-NC or connect to P45
10	PO-	Ground	Negative terminal (*PoE)	-NC or connect to P78
-	Shell	Earth	Chasis Ground	Protective earth

7. 10/100BASE-TX Magnetics Modules (Electrical specifications @ 25°C)

No	Turns Rations		Insertion Loss (max)	Return loss (dB min)				Crosstalk (dB min)		
	TX (±3%)	RX (±3%)		1M~30M	40M	50M	60M~80M	30M	60M	100M
0	1CT:1CT	1CT:1CT	-1.4	-16	-14	-13	-12	-40	-35	-30
1	1CT:1.41CT	1CT:1CT	-1.4	-16	-14	-13	-12	-40	-35	-30
2	1CT:1.25CT	1CT:1CT	-1.4	-16	-14	-13	-12	-40	-35	-30

Primary inductance: 350uH minimum OCL with 8mA bias current@100kHz,0.1Vrms

8. LED characteristics

Standard LED	Wavelength	Forward (max)	Forward (Typ)	Current (max)
Yellow	590-593nm	2.5V	2.1V	20mA
Green	568-574nm	2.5V	2.2V	20mA

9. Mechanical characteristics (unit: mm)

1. Products shell hole (Recommended value)

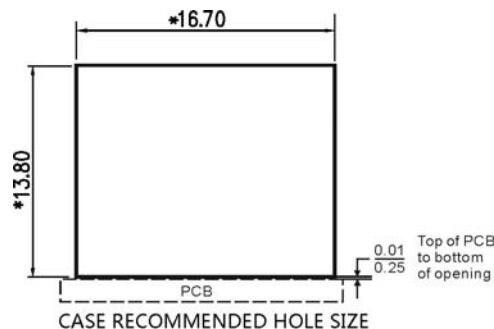

2. Front view

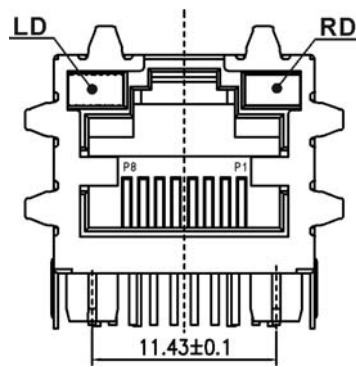

3. Bottom view

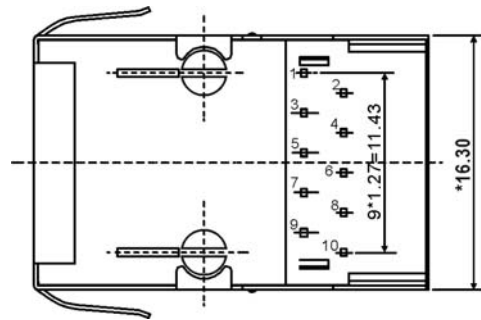

4. Side view

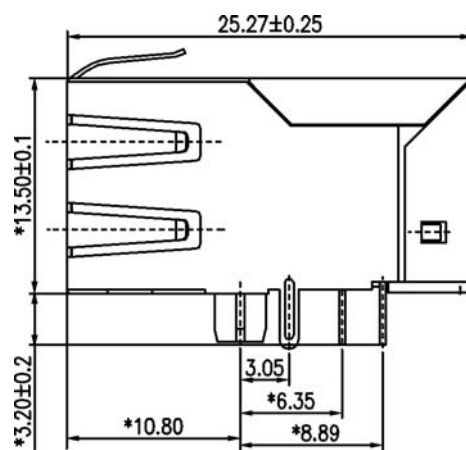

5. Recommended PCB layout (NPPort footprint)

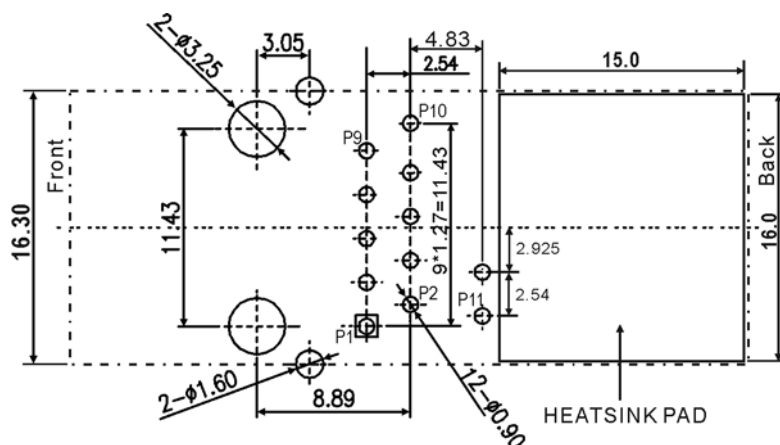

P.C.B RECOMMENDED HOLE LAYOUT SEEN FROM COMPONENT SIDE.
ALL CENTERLINE DIMENSIONS ARE BASIC

Other Related documentation

Name	Description
<i>NPPort-EVB user manual</i>	<i>To evaluate the performance of NPPort, and demonstrates serial to Ethernet.</i>
<i>NPPort data sheet</i>	<i>Support PoE function of the RJ45 module</i>

For details contact your local CONEXTOP representative or CONEXTOP directly:

Call OEM sales support at 86-755-26505615

More details about NPPort at <http://www.conextop.com>

©CONEXTOP Technologies – November 2007 – All rights reserved

The CONEXTOP corporate logo is a registered trademark of CONEXTOP Technology. All other names are the property of their respective owners.

©2007 CONXTOP,Inc. All rights reserved. CONEXTOP, NPPort, with its patent-pending technology. All other trademarks are the property of their respective owners. Specifications subject to change without notice.

All rights reserved.